

## Adaptation between Pulsed Kicker Magnets and Pulser Circuits

Guido Blokesch and Michael Osemann\*, Ampegon  
Henning Bach and Nils Hauge, Danfysik

Ampegon PPT GmbH, Feldstrasse 56, 44141 Dortmund, Germany  
\*corresponding author michael.osemann@ampegon.com

### Introduction

The right adaptation between pulsed magnets and pulser circuits is a very important design criteria for kicker and septa in particle accelerators.

The article describes aspects of mechanical and high voltage rf matching not only in between the magnet and pulser system but also the adaptation to the accelerator facilities. The cooperation between both, designers of magnets and electrical pulse circuits, is necessary for the pulse quality and EMC.

The pulse rise time and pulse length defines whether the kicker magnet can be arranged inside or outside of the vacuum chamber. The different approaches for the inside or outside chamber kickers will be presented.

Thereby the important factors are the feedthroughs of the vacuum chamber. These electrical passing points used for in- and outputs for termination and reflection kickers have an essential influence on the pulse quality. Thereby the type and form of connections in reference to the electrical coupling or decoupling of the magnet and circuit to ground will be discussed.

### Kicker Magnets inside or outside the Vacuum

The decision whether the conventional dipol kicker magnet should be installed inside or outside of the vacuum can be roughly described with the following criteria

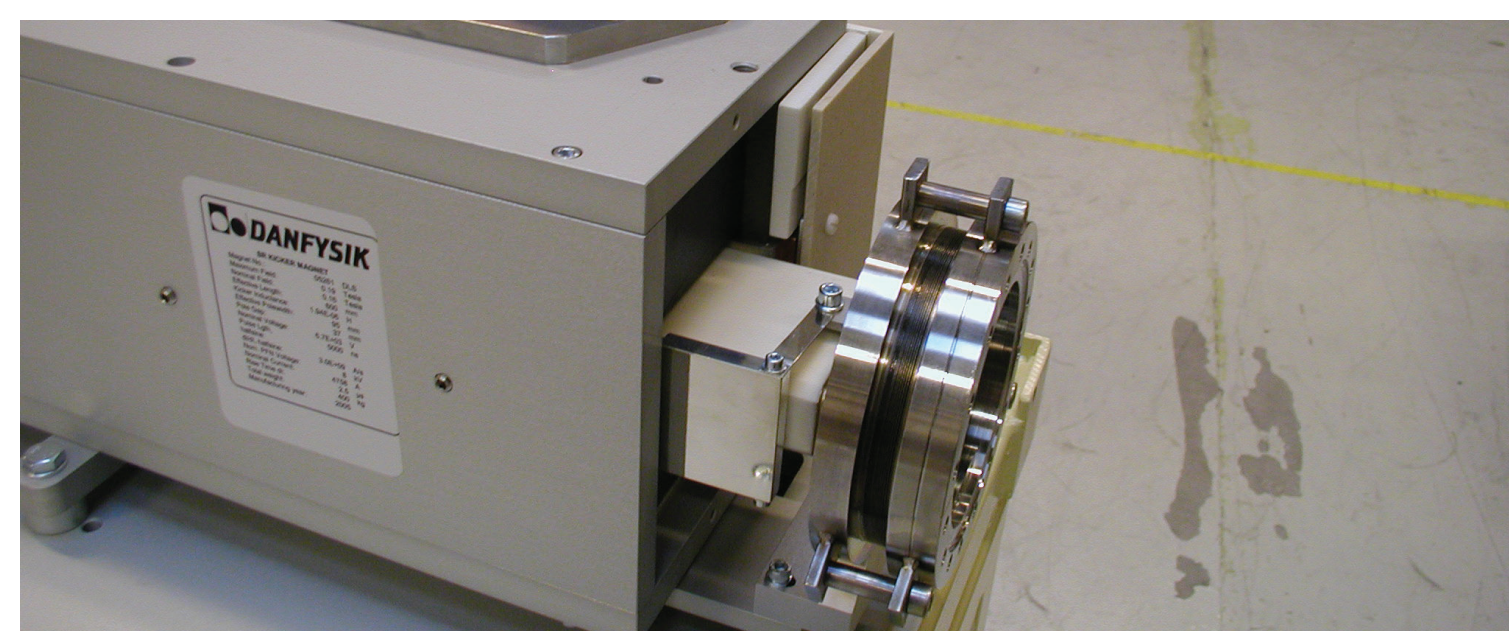

Figure 1: Kicker outside installation at air with metallized ceramic vacuum chamber

Typical: Sine half wave  $>1 \mu\text{s}$  pulse length and up to 10 kA pulse current.

#### Advantages

- Nearly constant impedance for the particle beam through metallized ceramic chambers, 50 nm to  $2 \mu\text{m}$  (titanium, stainless steel), compromise between ohmic wall resistance and thermal conductivity
- Easy direct connection (tape connectors) of the magnet without vacuum feedthroughs

#### Disadvantages

- Rise time depends on metallisation thickness inside of the ceramic chamber (low pass filter)
- Pulse voltages are limited though distance against ground depends on insulation material

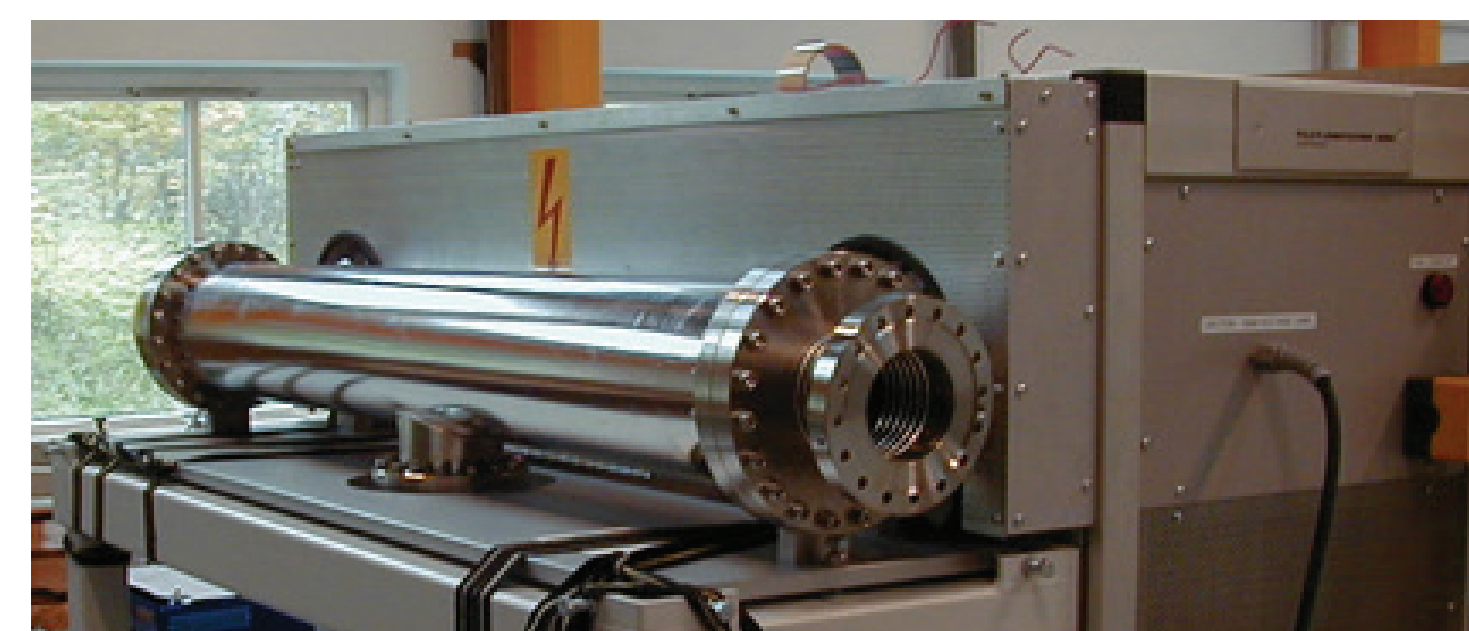

Figure 2: Kicker installation in vacuum with feedthroughs

Typical: Rectangular pulse forms with rise time  $<100 \text{ ns}$  pulse length several  $\mu\text{s}$  and pulse currents up to 10 kA.

#### Advantages

- High rise time ( $<100 \text{ ns}$ ), direct magnetic field on the beam (no low pass filter through the vacuum chamber) rise time depends on inductance and pulse current
- Less magnet gaps leads to lower pulse current
- HV insulation through vacuum, factor 3-4 in reference to air
- Tight distances between connectors and to ground (limited through residual gases and radiation level)

#### Disadvantages

- Electromagnetic interaction from the beam with the surrounding components in the vacuum chamber; no constant

distance from the beam to wall, no constant beam impedance, wake fields  
-> solution: additional wall plates

- Electromagnetic interaction from the beam to the pulser circuit (transformer effect of the kicker magnet to the pulser; ion particle beams could have pulse currents  $>100 \text{ A}$  with  $<100 \text{ ns}$  pulse length -> wrong trigger of the pulser)
- Complicated HV feedthroughs depends on pulse (rise time inductance), high voltage level and grounding / common concept
- RF heating of the ferrite core could lead to passing the curie temperature

For systems with  $<100 \text{ ns}$  rise time and  $>0.5 \text{ kA}$  pulse current, the in vacuum kickers are preferred.

### Kicker Magnet Main Circuit

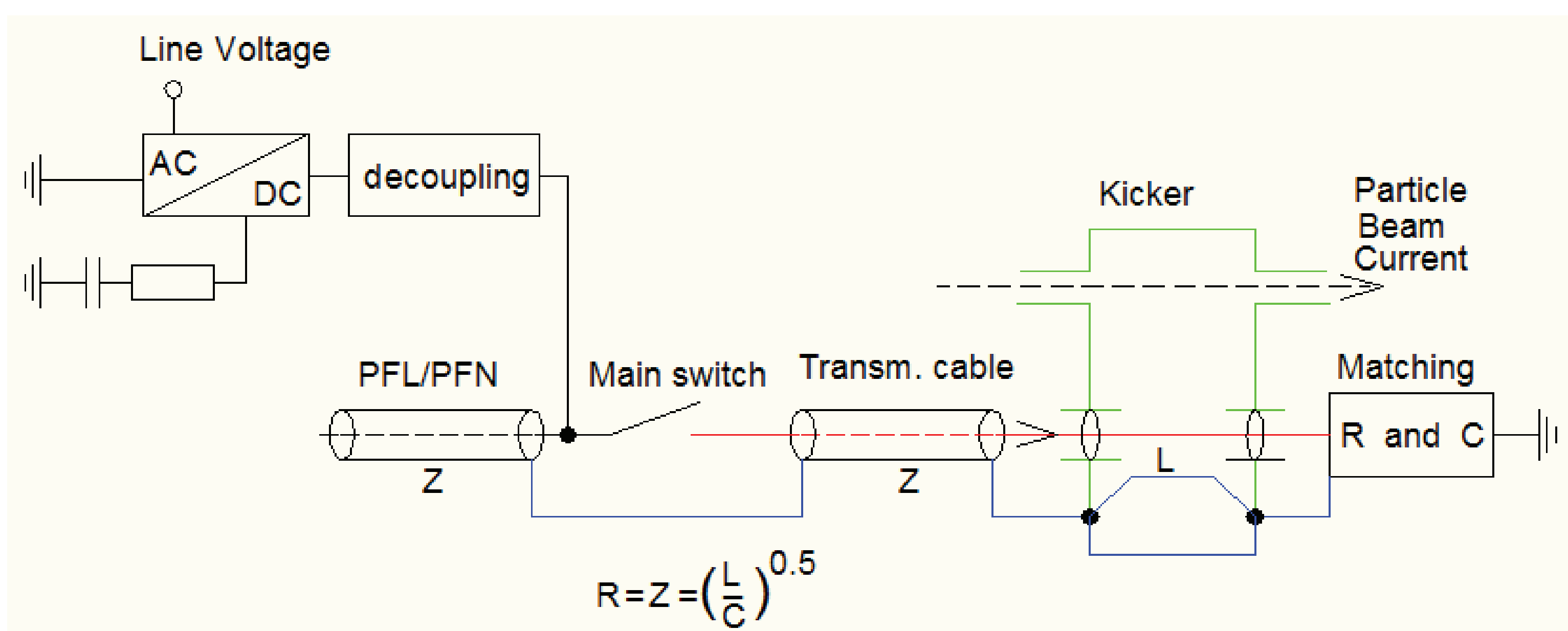

Figure 3: Shows a principle structure of a kicker magnet with a rectangular pulse generator. Problems: Parallel current paths via the vacuum chamber. The current will flow where the impedance is less. Even if there is a parallel path through the vacuum chamber wall most current will flow along the magnet in the copper screen. Especially for half sine and short flattop pulses, not for DC.

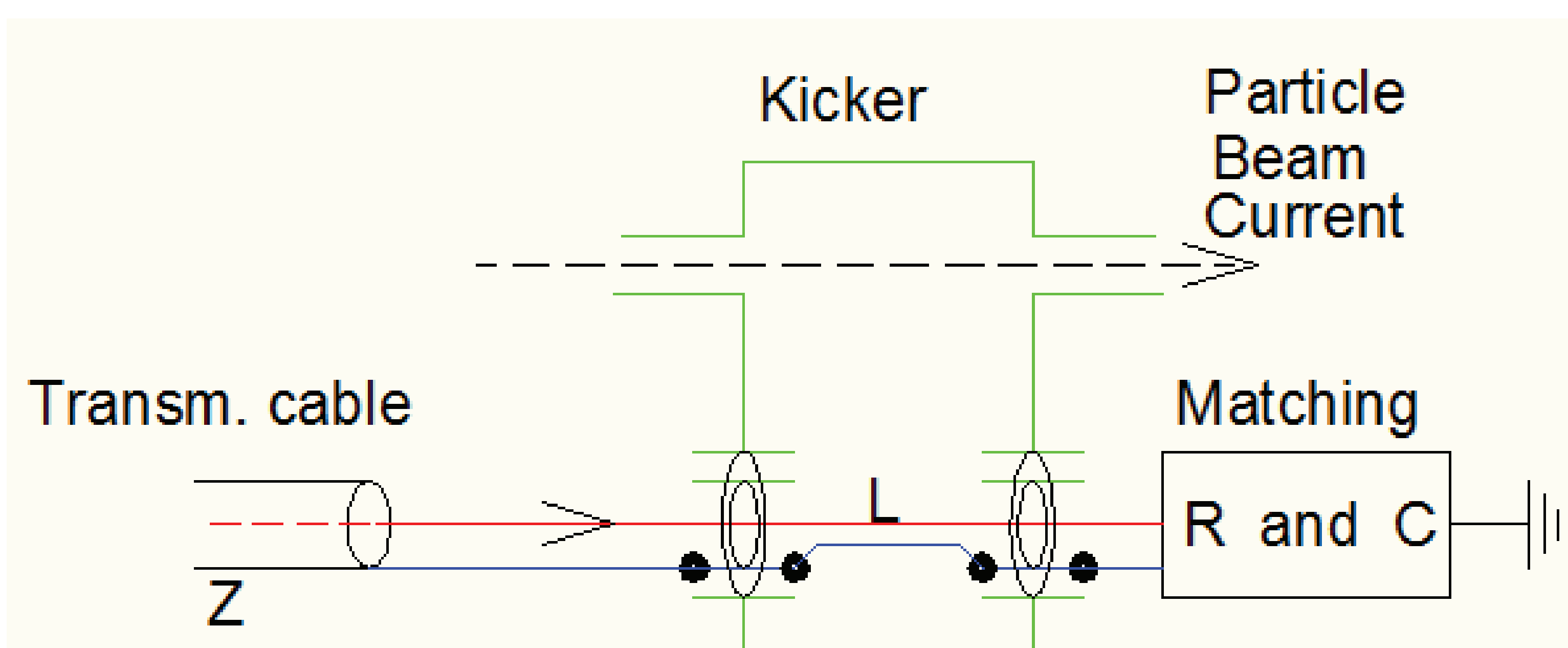

Figure 4: Shows a principle structure of a kicker magnet with a rectangular pulse generator and triaxial feedthrough to avoid parallel currents via the vacuum chamber.

### Alternative Feedthrough

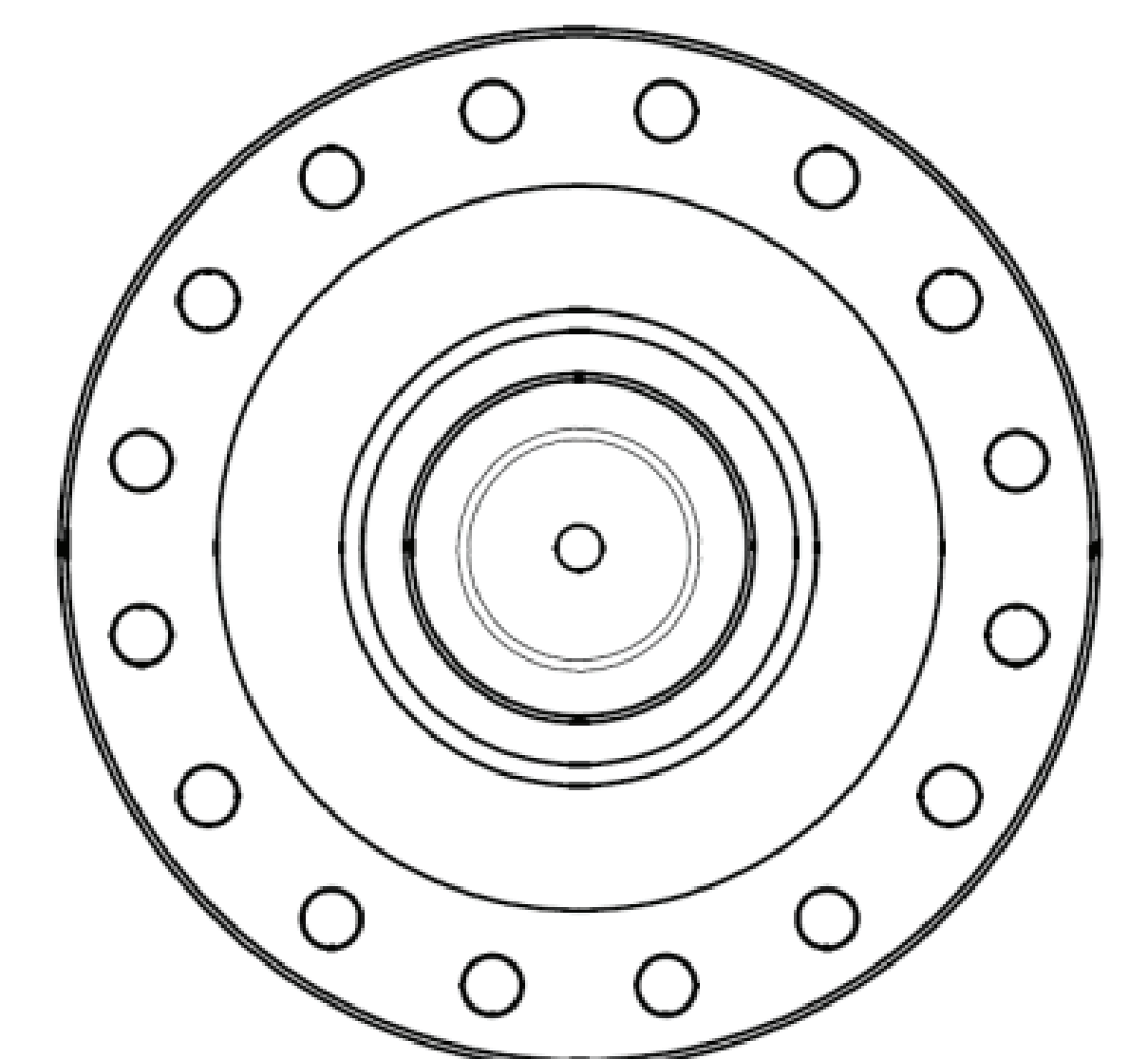
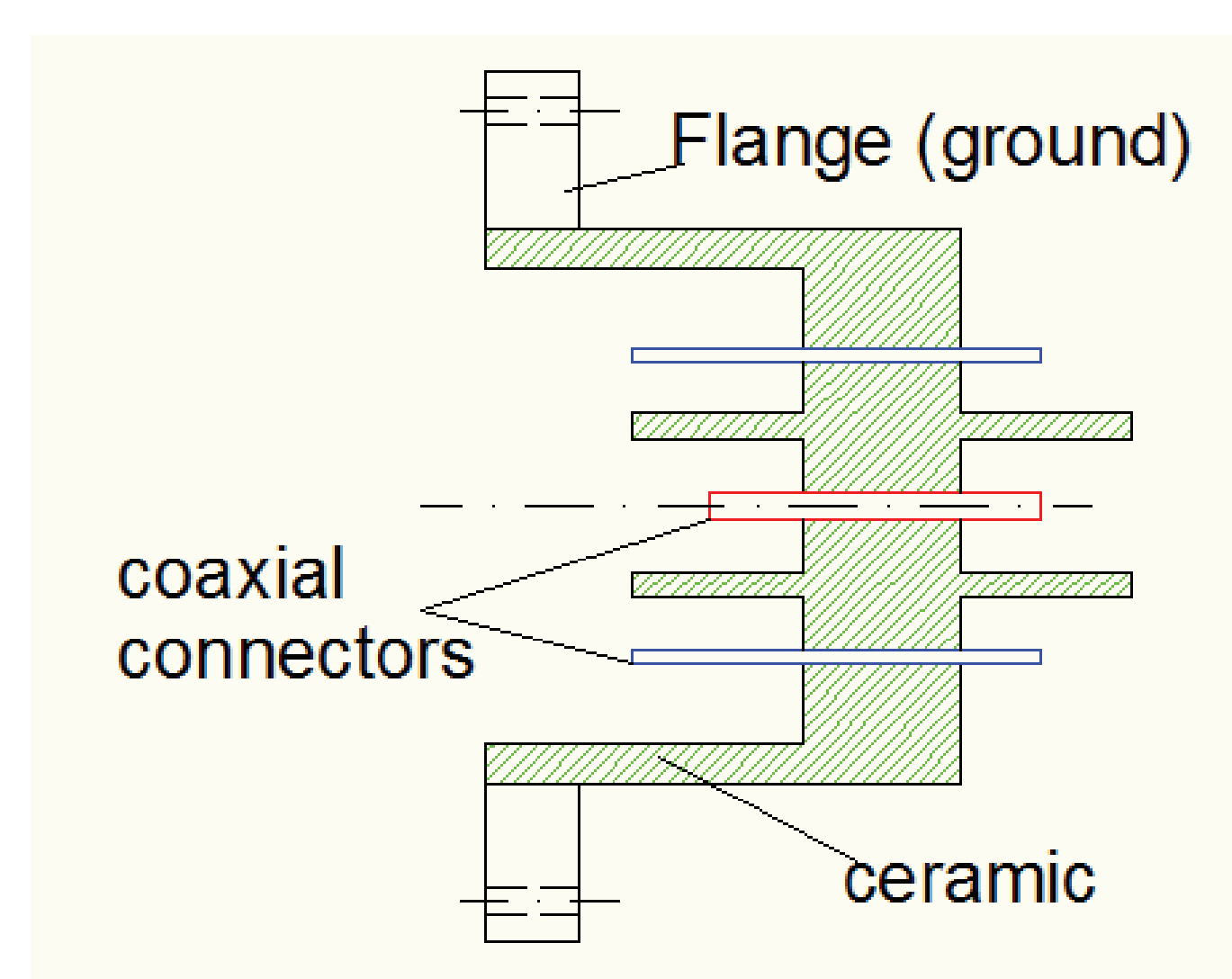

Figure 5: Triaxial feedthrough (2 insulated connectors) Conflat flange CF 100 (or larger) as triaxial feedthrough (flange on ground potential)

#### Advantages

- Filtering, EMC (no current over chamber), reduced effects on neighbor devices like beam monitors
- Better filtering of back triggering with ferrites to the pulser through separate connectors
- Insulation against ground (ground termination only on one point)